

# ATLANTIC: Structure-Aware Retrieval-Augmented Language Model for Interdisciplinary Science

Sai Munikoti, Anurag Acharya, Sridevi Wagle, Sameera Horawalavithana

Pacific Northwest National Laboratory  
Richland, WA, USA

{sai.munikoti,anurag.acharya,sridevi.wagle,yasanka.horawalavithana}@pnnl.gov

## Abstract

Large language models record impressive performance on many natural language processing tasks. However, their knowledge capacity is limited to the pretraining corpus. Retrieval augmentation offers an effective solution by retrieving context from external knowledge sources to complement the language model. However, existing retrieval augmentation techniques ignore the structural relationships between these documents. Furthermore, retrieval models are not explored much in scientific tasks, especially in regard to the faithfulness of retrieved documents. In this paper, we propose a novel structure-aware retrieval augmented language model that accommodates document structure during retrieval augmentation. We create a heterogeneous document graph capturing multiple types of relationships (e.g., citation, co-authorship, etc.) that connect documents from more than 15 scientific disciplines (e.g., Physics, Medicine, Chemistry, etc.). We train a graph neural network on the curated document graph to act as a structural encoder for the corresponding passages retrieved during the model pretraining. Particularly, along with text embeddings of the retrieved passages, we obtain structural embeddings of the documents (passages) and fuse them together before feeding them to the language model. We evaluate our model extensively on various scientific benchmarks that include science question-answering and scientific document classification tasks. Experimental results demonstrate that structure-aware retrieval improves retrieving more coherent, faithful and contextually relevant passages, while showing a comparable performance in the overall accuracy.

## 1 Introduction

The continuous advancement in natural language processing (NLP) has led to the development of various novel model architectures that overcome existing limitations and demonstrate state-of-the-art performances. The retrieval augmented language models (RALM) primarily address the grounding and scalability challenges in standard language models (LM). RALM aims to address these limitations by combining a LM with an external knowledge base. In this framework, the LM generates text conditioned not only on the input query but also on relevant knowledge retrieved from the knowledge base. The retrieved knowledge is usually the text chunks or passages from documents that pro-

vide factual grounding to contextualize the model’s predictions. In other words, this approach decentralizes model knowledge into parameters and external knowledge sources, thereby addressing the challenges of scalability and adaptability.

Typically in RALM, text data from an external knowledge base is segmented and encoded into vectors (also known as vector databases). The retriever component of RALM retrieves relevant documents based on the similarity between the query and vectors corresponding to documents in the database. Many existing RALMs rely solely on semantic/lexical information of the documents for retrieval. However, in certain scenarios, the structural relationship between documents can further support the retriever in retrieving contextually relevant documents. For instance, a scientific paper in materials science might reference papers that describe relevant advances in nuclear physics, and vice-versa. Having such relational information explicitly present in the scientific documents would allow the model to draw on the interdisciplinary scientific knowledge in a similar way to how scientists do. Thus, it would be beneficial to learn about the relationships between documents (e.g., citations, co-authorship, etc.) in a corpus of scientific publications and connect different scientific concepts.

To address the challenges of adequate structural component in RALM and retrieval faithfulness in science-focused tasks, we propose a novel model architecture (ATLANTIC) in this work that systematically incorporates structural and textual information into the RALM. We develop ATLANTIC on top of the standard RALM, ATLAS (Izcard et al. 2022) architecture. In comparison to ATLAS, we introduce new structural encoder component that uses the corresponding structural embeddings along with the text embeddings of the retrieved passages, and then fuse both embeddings for each passage before feeding them to the other language modeling components. The structural embeddings are obtained by a pretrained graph neural network on the document relationship graph. This mechanism explicitly incorporates the structural relationship of passages. We extensively evaluated the ATLANTIC model on scientific tasks, especially in regard to the faithfulness of the retrieved passages.

**Contributions** The specific contributions of this work are as follows:

- Novel mechanism to combine structural and textual information of scientific documents in the retriever of the RALM model.
- Structural encoder via a Heterogeneous Graph Transformer (HGT) model pretrained with document relationships.
- Propose novel evaluation metrics to measure the quality of retrieved documents on scientific tasks.

The rest of the paper is organized as follow. Section 2 provides a brief literature review and Section 3 describes the proposed methodology in details. While Section 4 outlines the experimental setup, Section 5 presents the performance analysis and finally Section 6 concludes the paper.

## 2 Related work

RALM is an active area of research driven by the goal of overcoming the limitations of language models’ limited contextual capacity and world knowledge (Li et al. 2022; Zhu et al. 2023). RALM primarily consists of Retriever (text encoder) and Reader (language model). In the earlier RALM works, retriever is kept frozen and only language model is trained. REALM (Guu et al. 2020) and RAG (Lewis et al. 2020) are some of the initial works that focused on retrieving relevant passages from large text corpora to provide additional context to LM. REALM trains an encoder to retrieve passages and pass them to the language model. RAG retrieves documents for Question answering using BM25 and fine-tunes a T5 model along with retrieved passages. Similarly, RETRO (Borgeaud et al. 2022) combines a frozen Bert retriever, a differentiable encoder and a chunked cross-attention mechanism to predict tokens based on an order of magnitude more data than what is typically consumed during training. REPLUG (Shi et al. 2023), PKG (Luo et al. 2023), and LLM-AMT (Wang, Ma, and Chen 2023) propose an alternate plug and play framework where a trainable or even frozen retriever is fused with off-the-shelf frozen language model. DSP (Khattab et al. 2022) provides an in-context learning retrieval augmented framework where retrieved passages act as prompts to the frozen LM. HIND-SIGHT (Paranjape et al. 2021) and ATLAS (Izacard et al. 2022) are among few works in the third category where both the retriever and language model are trained in an end to end manner (Hu et al. 2023; Munikoti et al. 2023; De Jong et al. 2023). ATLAS experiments with various designs (in terms of loss functions, pretraining objectives) and training configurations (e.g., query side finetuning vs. full index update) for RALMs with a specific focus on the few-shot learning ability. However, these works solely rely on semantic/lexical information for retrieval augmentation.

In parallel, there are some efforts that looked at incorporating structured knowledge in the form of knowledge graphs. Graph-Retriever (Min et al. 2019) is one of the initial works that iteratively retrieves passages based on the passage relationships, and uses a passage graph to improve passage selection in an extractive reader. KAQA (Zhou et al. 2020) emphasizes improving both document retrieval and candidate answer reranking by considering the relationship between a question and the documents (termed as

a question-document graph), and the relationship between candidate documents (termed as a document-document graph). KG-FiD (Yu et al. 2021) applies KG to a more advanced Fusion in Decoder (FiD) architecture. It uses a graph neural network (GNN) to re-rank the passages obtained from the retriever and selectively pass a top few for further processing into the LM. However, these graph-based RALMs have major shortcomings in terms of (i) accommodating an extra trainable GNN component thereby increasing the computational complexity of the framework; (ii) ranking is not an explicit way of incorporating structural relationships.

## 3 Methodology

Our approach is based on the ATLAS architecture (Izacard et al. 2022), which is state-of-the-art RALM. ATLAS consists of a BERT-based *Retriever* model that retrieves top-k passages and feeds along with the input query to the *Reader*, i.e., T5-based LM. The basic architecture of our ATLANTIC model is kept the same as that of ATLAS, but we introduced new components and modified the coupling between *Retriever* and *Reader*. In ATLANTIC, given the input query, *Retriever* retrieves top-k passages from the input text corpus based on semantic relationship. Unlike ATLAS, which directly passes these top-k passages to the LM, we obtain their structural encodings (embeddings) by leveraging their structural relationships. The structural embeddings are then appended with their semantic counterparts as obtained via *Retriever* encoder, before feeding them to the LM. Figure 1 depicts the overview of ATLANTIC architecture with different components and their interactions. Structural encoding provides extra context to the LM for generation, and it also improves the *Retriever* model to retrieve better passages whose semantic and structural identity better aligns with the target generation. Different components of ATLANTIC architecture are described in detail below.

### 3.1 Creating Heterogeneous Document Graph

Structural encodings for the passages are obtained by leveraging their structural relationships in the form of a Heterogeneous Document Graph (HDG). HDG offers plenty of new information that is otherwise ignored in standard semantic-only RALM. We first construct the document graph for the text corpus using existing relational information. Documents act as nodes, and the relationship between the documents act as links. Since our focus is in the scientific domain, we choose a text corpus of scientific articles (research papers), where four kinds of links exist. The link types are co-citation, co-topic, co-venue, and co-institutions where the co-citation links are the majority. If document *A* cites document *B*, then they are connected via a co-citation link. Similarly, if documents belong to the same topic, there is a co-topic link connection. Co-venue and co-institute are applicable when two documents belong to the same publication venue and an institute, respectively. There is a one-to-one mapping between the document and the node in the document graph.

Following earlier works (Karpukhin et al. 2020; Yu et al. 2021), each document (article) in our text corpus is split into

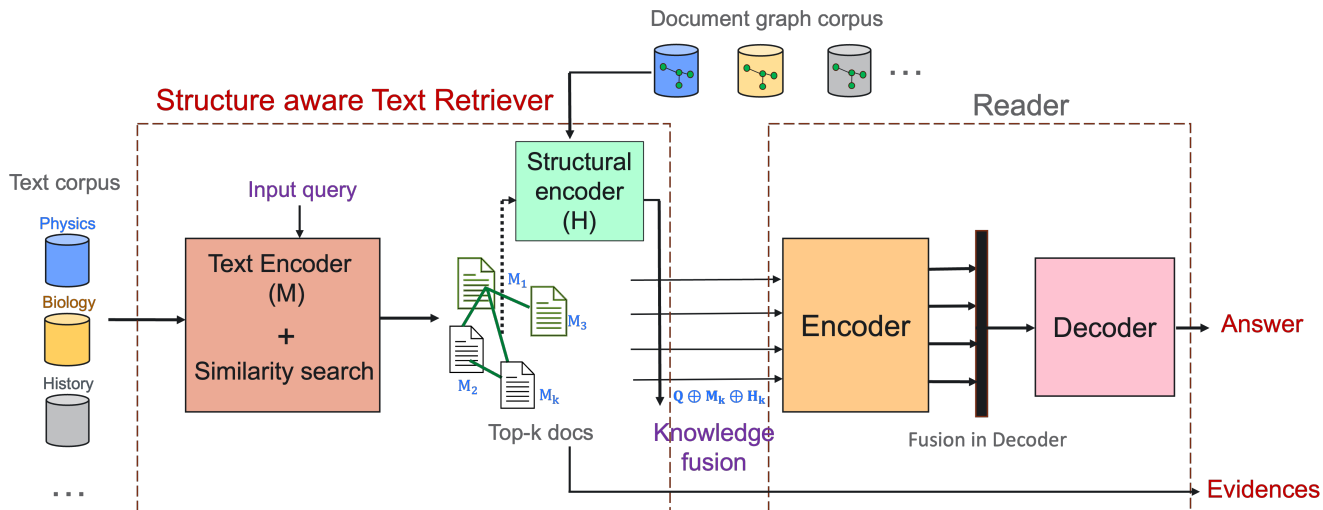

Figure 1: Proposed ATLANTIC framework (docs referred to passages). Structural embeddings ( $H_k$ ) quantify the cross-document connections among the retrieved docs, which could be useful for multi-hop (multi document) reasoning. For illustration, doc 1 and doc 3 are highlighted since their information could offer relatively more relevant context to fetch the answer for the given query.

various disjoint text chunks of 100 words or 512 token. Each chunk is called a *passage*, which are fundamental retrieval units. The relationship among the passages is formed based on document-level relations, i.e., if document A and document B are connected via co-topic, then we assume all passages from document A are connected with that of document B. This is achieved by associating all the passages of a document with the same embedding, i.e., their document embedding, so that passages from related documents share similar representation.

### 3.2 Text and structure fused knowledge augmentation

This section describes the proposed framework of fusing text and structural information in the retriever which extracts contextually relevant passages from the external document corpus.

**Text-based Retrieval** Similar to ATLAS, the retriever in ATLANTIC is based on the Contriever (Izacard et al. 2021), which retrieve documents based on continuous dense embeddings. It uses dual encoder architecture so that query and passages are embedded independently by a transformer encoder (Karpukhin et al. 2020). Suppose there are  $N$  passages in the text corpus  $\{p_1, p_2, \dots, p_N\}$ , then their embeddings can be represented as:

$$\mathbf{M}_i = \text{Contriever}(p_i) \forall i \in \{1, 2, \dots, N\}, \quad (1)$$

where  $M_i$  belongs to  $\mathbb{R}^D$  and  $D$  is the hidden dimension of the embedding vector. For each input query, the retriever conducts a dot product similarity search between the embedding of the query ( $Q$ ) and embedding of all passages ( $M$ ) as obtained via Contriever, and returns  $N_k$  passages with the highest similarity scores. Thus, passages are solely retrieved

based on their semantic equivalence with the query.  $N_k$  is substantially smaller than  $N$  since we are only interested in extracting a small set of the most relevant passages, typically in the order of tens or hundreds, from the corpus containing millions of passages.

**Structural encoding** We see in the previous subsection that the retriever model retrieves top  $N_k$  passages independently based on the semantic/lexical similarity between the query and each passage, and then passes the text embeddings of these  $N_k$  passages to the LM without accounting for inter-passage relationship. To address this shortcoming, we propose to incorporate the structural relationships via extra embeddings, which we termed as structural embeddings (or encodings). The structural embeddings are then concatenated with text embeddings and passed to the reader (i.e., LM). The structural embeddings are obtained via a structural encoder, which is basically a frozen graph neural network (GNN) model. Particularly, we leverage the heterogeneous graph transformer (HGT) model (Hu et al. 2020) to fetch the structural embeddings since they can explicitly account for heterogeneous relationships (co-citations, co-topic, co-venue, co-institute) in the document graph. We first train HGT on the document graph using link prediction as the pre-training objective (Hu et al. 2020). The trained HGT is used as a frozen model to encode passages in the ATLANTIC pipeline. The structural embedding of a particular passage  $p_i$  as obtained from HGT can be represented as:

$$\mathbf{H}_i = \text{HGT}(p_i) \forall i \in \{1, 2, \dots, N_k\}. \quad (2)$$

$H_i$  is the output from the final encoding layer of the HGT, which basically aggregates the essential information from the neighbors of  $p_i^{\text{th}}$  passage in the retrieved set  $\{p_1, p_2, \dots, p_{N_k}\}$ . This mechanism efficiently utilizes the

structural relationships from the document graph. All of the passages belong to a document share the same embedding, i.e., their document embedding as obtained by pretrained HGT. It is worth noting that one can use any GNN model to fetch structural embeddings, and the HGT used over here is for illustration purpose.

**Knowledge Fusion** The semantic retriever and structural encoder provide text embeddings ( $M$ ) and structural embeddings ( $H$ ) of top-k retrieved passages, respectively. We concatenate text and structural embeddings for each passage to generate new aggregate embedding  $E_i$  as shown below:

$$\mathbf{E}_i = \mathbf{M}_i \oplus \mathbf{H}_i \quad \forall i \in \{1, 2, \dots, N_k\}, \quad (3)$$

where  $\oplus$  stands for concatenation operator. The aggregate embedding  $\mathbf{E}$  captures semantic as well as structural information that enable models to retrieve knowledge from multiple interdisciplinary documents.  $\mathbf{E}'$  is the final embedding, which is an input for the reader model. It is obtained by concatenating query embedding  $\mathbf{Q}$  with the aggregate embedding of the passages  $\mathbf{E}$  as shown below:

$$\mathbf{E}' = \mathbf{Q} \oplus \mathbf{E}. \quad (4)$$

Since our framework leverages the frozen pretrained GNN model, the novel structural encoder will not induce any computational bottleneck, and its computational complexity is equivalent to that of ATLAS architecture.

### 3.3 Pretraining objectives and loss function

The retriever and reader (LM) model in ATLANTIC are trained end to end using Perplexity distillation as the loss functions (Izacard and Grave 2020; Singh et al. 2021). The retriever gets feedback from the output of the LM in terms of perplexity score such that it should pick such passages with respect to input query and their structural relationship, which eventually improves the LM perplexity scores. In this regard, KL-divergence between the passages distribution of the retriever and the passages posterior distribution is minimized. The loss function can be written as:

$$L_i = \frac{\exp(\log p_{LM}(\mathbf{a}|\mathbf{E}'_i))}{\sum_{i=1}^k \exp(\log p_{LM}(\mathbf{a}|\mathbf{E}'_i))}, \quad (5)$$

where  $\mathbf{a}$  denotes the perplexity score of the LM and  $p_{LM}$  is the likelihood.

We employ masked language modeling (MLM) (Raffel et al. 2020) as a pretraining objective. In the given chunk of  $M$  tokens, we sample  $m$  spans of an average length of three tokens, thereby leading to a mean masking ratio of 15%. Then we replace the selected span of tokens with an individual sentinel token. During training, the input to the encoder of the LM is the corrupted (masked) sequence, and the target is then the dropped-out tokens delimited by their sentinel tokens (e.g.,  $\langle \text{extra\_id.0} \rangle$ ,  $\langle \text{extra\_id.1} \rangle$ , etc.). The retriever in our ATLANTIC model retrieves passages using the masked query, but replaces the special mask tokens with a mask token supported by the retriever vocabulary (Izacard et al. 2022).

## 4 Experimental Setup

In this section, we report the experimental setup used to evaluate the ATLANTIC model on science focused benchmarks. We outline the datasets, baselines, benchmarks, and training details.

### 4.1 Datasets

We focus on evaluating the ATLANTIC model on its ability to understand scientific language and retrieve contextually relevant passages from multiple scientific knowledge sources. We leverage S2ORC (Lo et al. 2019), which is a large corpus of curated 31.1M English-language scientific papers. We preprocess the S2ORC (Lo et al. 2019) dataset to create a collection of 354M text passages. Each passage has a maximum of 512 tokens, or 100 words, that are concatenated with the corresponding title of the document the passage belongs to. Our text corpus captures 19 different scientific domains from the S2ORC collection, which are as follows: Art, Philosophy, Political-Science, Sociology, Psychology, Geography, History, Business, Economics, Geology, Physics, Chemistry, Biology, Mathematics, Computer Science, Engineering, Environmental science, Material science, Medicine. In regard to structural data, we construct a heterogeneous document graph as described in Section 3.1. Table 4 (see Appendix) shows the statistics of the S2ORC knowledge graphs which we used to extract the heterogeneous document graphs for each domain. We use these graphs to train a structural encoder model for each domain.

### 4.2 Baseline Models

To demonstrate the advantages of RALMs on scientific tasks, we choose T5-lm-adapt model (Raffel et al. 2020) as a baseline model, which is a standard LM trained on C4 corpus. We took the original ATLAS model as a baseline, which is pretrained with common crawl (CC) and Wikipedia on top of the T5 model. In addition to this pretrained ATLAS, we also leverage ATLAS-Science model from scratch with the S2ORC scientific text dataset. For a fair comparison with ATLAS, we initialize the ATLAS-Science model with the T5-lm-adapt model and trained jointly with retrieval model, *Contriever* (Izacard et al. 2021). Table 1 summarizes the baseline model variants with the details of pretraining data.

### 4.3 Benchmarks

We use two different kinds of scientific benchmarks for training (and finetuning) and evaluating the models. The first benchmark is the SciRepEval (Singh et al. 2022) which provides 25 challenging tasks across four formats: classification, regression, ranking, and search. In this work, we focus on the classification formatted tasks, *Fields of study (FoS)* and *MAG* due to two main reasons. First, we need benchmark tasks that test the ability of the models to understand diverse scientific domains and disciplines. FoS tasks include instructions from several disciplines involving existing S2ORC domains as well as new ones. For instance, FoS task tests the ability of the model to recognize which domain the given text passage belongs to. Second, we want to evaluate on specific instruction template to avoid any prompting bias.

Table 1: Summary of different pretraining, instruction tuning and benchmark datasets used across baselines and ATLANTIC models.

Model	Modality	Pretraining		Instruction Tuning		Evaluation	
		Retrieval corpus	Data	Retrieval corpus	Data	Retrieval corpus	Data
T5	Text	N/A	C4	N/A	FOS	N/A	FOS
					MMLU		MAG
					MMLU		MMLU
ATLAS	Text	CC+Wiki	Wiki	S2ORC	FOS	S2ORC	FOS
					MMLU		MAG
					MMLU		MMLU
ATLAS-Science	Text	S2ORC	S2ORC	S2ORC	FOS	S2ORC	FOS
					MMLU		MAG
					MMLU		MMLU
ATLANTIC	Text + Structure	S2ORC	S2ORC	S2ORC	FOS	S2ORC	FOS
					MMLU		MAG
					MMLU		MMLU

Our second evaluation benchmark is MMLU (Hendrycks et al. 2020), which contains 57 multi-choice question answering datasets (domains) obtained from real examinations designed for humans. These datasets cover a wide range of science topics, including high school science, law, and medicine. They are broadly categorized into four subsets: humanities, social sciences, STEM, and “other”. We focus on few-shot learning, which leverages 5 training examples per domain. Along with the 5-shot examples, we also leverage additional training examples from other multiple-choice QA tasks provided by the MMLU authors, namely MCTest (Richardson, Burges, and Renshaw 2013), RACE (Lai et al. 2017), ARC (Clark et al. 2018) leading to 95k training and 14k testing examples.

#### 4.4 Training details

For training, we create our text corpus and document graph as described earlier. We provide the collection of 354M scientific text passages as an external text retrieval corpus for all our finetuning and evaluation tasks. In this regard, we encode all the text passages with the *Contriever* model and construct a document index in the FLAT (Izacard et al. 2022) mode for faster retrieval. Retrieval requires frequent updates to the embeddings correspond to the retrieved documents. However, this update is costly given the size of the retrieval corpus. To address these scalability issues, we opt for *query side finetuning* approach, which was originally introduced in the ATLAS model (Izacard et al. 2022). This approach is very efficient for model training since it keeps the document encoder frozen while only training the parameters of the query encoder. For a fair comparison, all the models are trained for the same number of tokens. All our experiments are based on base 220M model architecture unless explicitly mentioned.

For passage structural embedding, we first train the HGT on the heterogeneous document graph. Thereafter, we obtain the structural embedding of each passage by fetching their respective document encoding via a trained HGT, and consequently saved it in the corresponding index database along with the passage text. Table 1 summarizes the pretraining, instruction tuning, and evaluation data used for the baselines

and our ATLANTIC model. We pretrained the models for 20000 steps using AdamW as an optimizer with an effective batch size of 32. We retrieve 20 passages per query during training. All experiments are conducted on 16 A100 80 GB GPUs in a Linux server.

We report the performance of the standalone LLM i) T5 (pretrained with C4), ii) ATLAS model (pretrained with CC and Wikipedia), iii) ATLAS-Science model (pretrained with S2ORC text) and (iv) ATLANTIC (pretrained with S2ORC text and document structure) proposed structural-aware RALM in Section 5.

#### 4.5 Fine Tuning

Previous research (Izacard et al. 2022) has shown that ATLAS model is able to learn knowledge-intensive tasks with very few training examples (i.e., few shot learning). To allow the model to perform on the scientific downstream tasks, we tune the model with scientific instructions. We adopt instruction finetuning for FoS and MAG tasks with a classification style template<sup>1</sup>.

These templates help guide the model to generate the scientific domain that each passage belongs to. We tune the model with *Fields of study (FoS)* training data after converting them to instructions. This process resulted in 541, 218 training instructions that were used to perform instruction tuning. For a fair comparison, we tune all baseline models (T5, ATLAS, ATLAS-Science) with these instructions. There are 68, 147 and 3, 751 test instructions in the FoS and MAG tasks, respectively. We use MAG instructions to test the out-of-distribution task performance in a zero shot manner. We followed the same configurations to finetune the model with the MMLU training data as that of ATLAS (Izacard et al. 2022).

<sup>1</sup>FoS/MAG Instruction Template: ### Below is an input containing a title-abstract pair. Classify this input into one or more possible Field of Study categories. ### Possible Categories: [...] ### Input: ## Title: [...] ## Response:

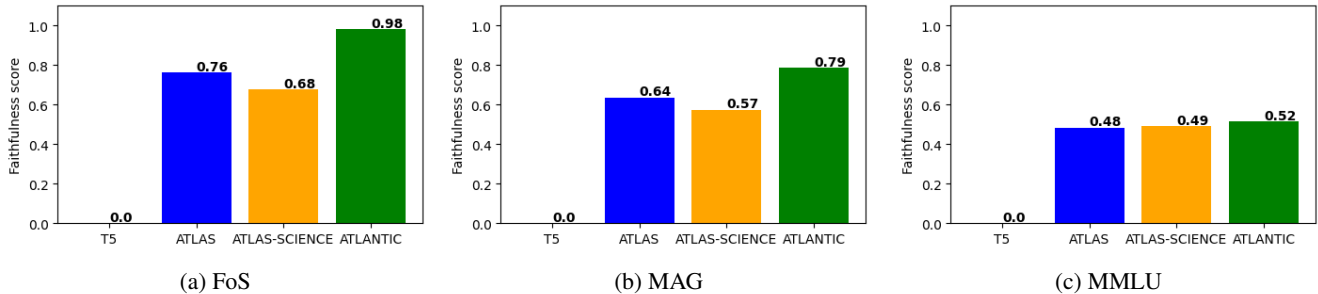

Figure 2: Faithfulness scores across FOS, MAG and MMLU benchmarks. Faithfulness score is the harmonic mean between the accuracy and relevance of the retrieved passages, which gives a holistic view on the trustworthiness of the model.

## 4.6 Evaluation metrics

We use Exact Match (EM) and F1-Score to evaluate the accuracy of generations from RALMs. EM metric evaluates the exact token overlap between the ground truth and generated answers. Furthermore, in existing RALM works, the retriever is mostly evaluated via the generation quality of the language model. However, we want to independently evaluate retriever. In this regard, we design two metrics to evaluate the relevance and diversity of the extracted evidences from the retriever: the *query relevance* and *diversity* metrics. The query relevance metric calculates the semantic similarity of the extracted passages with the input query via their embeddings. Similarity scores are obtained via the dot product of the embeddings. The diversity metric calculates the ratio of the unique evidences in comparison to the total evidences. We also devise a new metric, *faithfulness score*, which incorporates the individual performance of both retriever and language model to evaluate the aggregate performance of RALM. Faithfulness score is a measure combining generation accuracy and relevance score of the retrieved passages via their harmonic mean. It is inspired from F1-Score so that it weights the two metrics (accuracy and relevance score) in a balanced way, requiring both to have a higher value for the faithfulness score value to be high.

## 5 Performance Analysis

In this section, we analyze the performance of ATLANTIC and other baseline models to answer two research questions (RQ 1) and (RQ 2). We evaluate the performance of models in terms of generation accuracy and quality of the extracted evidences.

**(RQ 1)** Does retrieving structural knowledge help to improve the overall model performance?

**(RQ 2)** How useful are the evidences generated from structure-aware RALMs to justify model predictions in science tasks?

**Retrieving structural knowledge helps RALMs to perform better than just retrieving textual knowledge** To address (RQ 1), we evaluate the model performance on *Fields of study (FoS)*/MAG and *MMLU* benchmarks and compare the performance across ATLANTIC and ATLAS model variants (as shown in Table 1). For FOS and MAG

evaluation, we first finetune all models with only the *FoS* training instructions (as described in Section 4.5) and then evaluate on *FoS* (in-distribution) and *MAG* (out-of-distribution) test splits. Figures 2a and 2b report the performance of the model. We observe that ATLANTIC model outperforms all other baselines in these benchmarks. This indicates that the proposed model has better aggregate performance in terms of retrieving relevant passages and generating correct answers in science tasks.

Table 2: Models’ ablation study to evaluate performance on MMLU

Model	Mean accuracy	Evidence Relevance
T5	0.331	N/A
ATLAS	<b>0.341</b>	0.825
ATLAS-Science	0.332	0.928
ATLANTIC	0.334	<b>1.135</b>

To further analyze the specific performance of the retriever and reader components, we tabulate their individual results in Table 3. First, we observe that the accuracy of all RALMs i.e., ATLAS, ATLAS-Science and ATLANTIC are better than that of T5 for both in-distribution *FoS* and out-of-distribution *MAG* tasks, demonstrating the importance of retrieval augmentation. Second, we observe that the ATLANTIC (85.0 %) is better than that of ATLAS (84.40 %) and ATLAS-Science (84.70 %) by a small margin of accuracy. This demonstrates that retrieving structural knowledge has low impact in the performance of the reader (language model) for scientific tasks. Third, this performance difference is in line with the MMLU benchmark, which we use to evaluate models in science question answering. To this end, we train all baseline and ATLANTIC models on the MMLU train split similar to the configurations provided in ATLAS (Izacard et al. 2022). We observe a minor difference in the performance of ATLAS and ATLANTIC as shown in Figure 2c and Table 2.

### Structure aware RALMs retrieve relevant passages to justify model predictions better than text-only models

To address the (RQ 2), we measure the quality of the retrieved passages across ATLAS, ATLAS-Science and ATLANTIC models. Though all models perform comparably in

Table 3: Models’ performance on in-distribution (SciDocs-FoS) and out-of-distribution (SciDocs-MAG) benchmarks.

Model	In-distribution Performance				Out-of-distribution Performance			
	Accuracy		Evidence Generation		Accuracy		Evidence Generation	
	EM	F1	Relevance	Diversity	EM	F1	Relevance	Diversity
T5	0.833	0.87	N/A	N/A	0.579	0.72	N/A	N/A
ATLAS	0.844	<b>0.92</b>	0.694	5E-5	0.591	<b>0.75</b>	0.69	60E-5
<b>ATLAS-Science</b>	0.847	<b>0.92</b>	0.564	8E-5	0.578	0.73	0.571	100E-5
<b>ATLANTIC</b>	<b>0.850</b>	0.89	<b>1.159</b>	<b>10E-5</b>	<b>0.595</b>	0.60	<b>1.163</b>	<b>120E-5</b>

the generated answers, they differ significantly in the quality of the passages that they retrieve to support the generated answers. For example, both ATLAS and ATLAS-Science models achieve low relevance scores in comparison to what achieved by the ATLANTIC model (Table 3). This suggests that the passages retrieved by ATLAS as evidences do not align accurately with the query. On the other hand, ATLANTIC retrieves more contextually relevant evidences. For example, ATLANTIC model retrieves passages from Chemistry and Biology domains as evidence while ATLAS model retrieves passages from Geology, and Social Science to support a query in Chemistry (see Appendix, Figure 3).

We also analyze the retrieved passes to support MMLU predictions. As reported in Table 2, ATLANTIC model records 1.135 relevance score over 0.825 in ATLAS. ATLANTIC retrieves passages from the query domains or at least related domains (such as physics-geology or humanities-social science) whereas ATLAS fails in retrieving passages even from the related domains where the query belongs to (see Appendix, Figure 4 and 5 for sample outputs). This suggests that having structured knowledge in the retrieval would help the model to extract most relevant passages to justify model predictions better than the models retrieving only textual knowledge.

**Discussions:** With our experiments, we can conclude that ATLANTIC offers better aggregate performance than baseline especially with respect to retriever. One potential explanation for observing minor gain in the language model accuracy despite improved retrieval in ATLANTIC could be that many of the questions in scientific benchmarks (at least the ones we used) are fact-based. For such factual queries, the language model may be less sensitive to the context from retrieved passages, and its more memorizable. The impact of retrieval will be evident in those benchmarks (queries) that are very context dependent. Therefore, even though our model is doing better in terms of aggregate performance due to better retrieval, its impact on the accuracy of the language model is low. We also urge the scientific community to develop benchmarks that test the ability of the models to perform on interdisciplinary science tasks.

We also noted that some design configurations may have some negative impacts on the effectiveness of the model. For example, the retrieval corpus was frozen during model training, but the query encoder was allowed to receive the gradient updates to address scalability issues (Izcard et al. 2022). This configuration may lead to the model being less able to generalize to scientific data than what was originally tested

for general web-quality data. It remains as a future work for developing solutions to address this trade-off between scalability and effectiveness of the RALMs.

## 6 Conclusion

In this paper, we present our model, ATLANTIC with a novel framework to integrate document structural knowledge into retrieval-augmented language models. To this end, we use a heterogeneous document graph to represent different types of relationships between scientific documents from more than 15 different scientific domains and develop a fusion strategy to combine the text and structure in the knowledge retrieval. We evaluate our model in multiple scientific benchmarks to test the quality of the retrieved scientific text passages. Our experiments demonstrate that retrieving structural knowledge helps retrieval-augmented language models to perform better overall than only retrieving textual knowledge. Specifically, structural knowledge helps the models to extract more faithful documents as evidence to support the model predictions. In the future, we will test our model on a wider range of scientific benchmarks and tasks (e.g., hypothesis generation), including those that require knowledge from multiple scientific disciplines.

## Acknowledgements

This work was supported by the NNSA Office of Defense Nuclear Nonproliferation Research and Development, U.S. Department of Energy, and Pacific Northwest National Laboratory, which is operated by Battelle Memorial Institute for the U.S. Department of Energy under Contract DE-AC05-76RLO1830. This article has been cleared by PNNL for public release as PNNL-SA-191272.

## References

- Borgeaud, S.; Mensch, A.; Hoffmann, J.; Cai, T.; Rutherford, E.; Millican, K.; Van Den Driessche, G. B.; Lespiau, J.-B.; Damoc, B.; Clark, A.; et al. 2022. Improving language models by retrieving from trillions of tokens. In *International conference on machine learning*, 2206–2240. PMLR.
- Clark, P.; Cowhey, I.; Etzioni, O.; Khot, T.; Sabharwal, A.; Schoenick, C.; and Tafjord, O. 2018. Think you have solved question answering? try arc, the ai2 reasoning challenge. *arXiv preprint arXiv:1803.05457*.
- De Jong, M.; Zemlyanskiy, Y.; FitzGerald, N.; Ainslie, J.; Sanghai, S.; Sha, F.; and Cohen, W. W. 2023. Pre-computed



- memory or on-the-fly encoding? A hybrid approach to retrieval augmentation makes the most of your compute. In *International Conference on Machine Learning*, 7329–7342. PMLR.
- Guu, K.; Lee, K.; Tung, Z.; Pasupat, P.; and Chang, M.-w. 2020. REALM: Retrieval-Augmented Language Model Pre-Training.
- Hendrycks, D.; Burns, C.; Basart, S.; Zou, A.; Mazeika, M.; Song, D.; and Steinhardt, J. 2020. Measuring massive multitask language understanding. *arXiv preprint arXiv:2009.03300*.
- Hu, Z.; Dong, Y.; Wang, K.; and Sun, Y. 2020. Heterogeneous graph transformer. In *Proceedings of the web conference 2020*, 2704–2710.
- Hu, Z.; Iscen, A.; Sun, C.; Wang, Z.; Chang, K.-W.; Sun, Y.; Schmid, C.; Ross, D. A.; and Fathi, A. 2023. Reveal: Retrieval-augmented visual-language pre-training with multi-source multimodal knowledge memory. In *Proceedings of the IEEE/CVF Conference on Computer Vision and Pattern Recognition*, 23369–23379.
- Izacard, G.; Caron, M.; Hosseini, L.; Riedel, S.; Bojanowski, P.; Joulin, A.; and Grave, E. 2021. Unsupervised dense information retrieval with contrastive learning. *arXiv preprint arXiv:2112.09118*.
- Izacard, G.; and Grave, E. 2020. Distilling knowledge from reader to retriever for question answering. *arXiv preprint arXiv:2012.04584*.
- Izacard, G.; Lewis, P.; Lomeli, M.; Hosseini, L.; Petroni, F.; Schick, T.; Dwivedi-Yu, J.; Joulin, A.; Riedel, S.; and Grave, E. 2022. Few-shot learning with retrieval augmented language models. *arXiv preprint arXiv:2208.03299*.
- Karpukhin, V.; Oğuz, B.; Min, S.; Lewis, P.; Wu, L.; Edunov, S.; Chen, D.; and Yih, W.-t. 2020. Dense passage retrieval for open-domain question answering. *arXiv preprint arXiv:2004.04906*.
- Khattab, O.; Santhanam, K.; Li, X. L.; Hall, D.; Liang, P.; Potts, C.; and Zaharia, M. 2022. Demonstrate-Search-Predict: Composing retrieval and language models for knowledge-intensive NLP. *arXiv preprint arXiv:2212.14024*.
- Lai, G.; Xie, Q.; Liu, H.; Yang, Y.; and Hovy, E. 2017. Race: Large-scale reading comprehension dataset from examinations. *arXiv preprint arXiv:1704.04683*.
- Lewis, P.; Perez, E.; Piktus, A.; Petroni, F.; Karpukhin, V.; Goyal, N.; Küttler, H.; Lewis, M.; Yih, W.-t.; Rocktäschel, T.; et al. 2020. Retrieval-augmented generation for knowledge-intensive nlp tasks. *Advances in Neural Information Processing Systems*, 33: 9459–9474.
- Li, H.; Su, Y.; Cai, D.; Wang, Y.; and Liu, L. 2022. A survey on retrieval-augmented text generation. *arXiv preprint arXiv:2202.01110*.
- Lo, K.; Wang, L. L.; Neumann, M.; Kinney, R.; and Weld, D. S. 2019. S2ORC: The semantic scholar open research corpus. *arXiv preprint arXiv:1911.02782*.
- Luo, Z.; Xu, C.; Zhao, P.; Geng, X.; Tao, C.; Ma, J.; Lin, Q.; and Jiang, D. 2023. Augmented Large Language Models with Parametric Knowledge Guiding. *arXiv preprint arXiv:2305.04757*.
- Min, S.; Chen, D.; Zettlemoyer, L.; and Hajishirzi, H. 2019. Knowledge guided text retrieval and reading for open domain question answering. *arXiv preprint arXiv:1911.03868*.
- Munikoti, S.; Acharya, A.; Wagle, S.; and Horawalavithana, S. 2023. Evaluating the Effectiveness of Retrieval-Augmented Large Language Models in Scientific Document Reasoning. *arXiv preprint arXiv:2311.04348*.
- Paranjape, A.; Khattab, O.; Potts, C.; Zaharia, M.; and Manning, C. D. 2021. Hindsight: Posterior-guided training of retrievers for improved open-ended generation. *arXiv preprint arXiv:2110.07752*.
- Raffel, C.; Shazeer, N.; Roberts, A.; Lee, K.; Narang, S.; Matena, M.; Zhou, Y.; Li, W.; and Liu, P. J. 2020. Exploring the limits of transfer learning with a unified text-to-text transformer. *The Journal of Machine Learning Research*, 21(1): 5485–5551.
- Richardson, M.; Burges, C. J.; and Renshaw, E. 2013. Mctest: A challenge dataset for the open-domain machine comprehension of text. In *Proceedings of the 2013 conference on empirical methods in natural language processing*, 193–203.
- Shi, W.; Min, S.; Yasunaga, M.; Seo, M.; James, R.; Lewis, M.; Zettlemoyer, L.; and Yih, W.-t. 2023. Replug: Retrieval-augmented black-box language models. *arXiv preprint arXiv:2301.12652*.
- Singh, A.; D’Arcy, M.; Cohan, A.; Downey, D.; and Feldman, S. 2022. SciRepEval: A Multi-Format Benchmark for Scientific Document Representations. *arXiv preprint arXiv:2211.13308*.
- Singh, D.; Reddy, S.; Hamilton, W.; Dyer, C.; and Yogatama, D. 2021. End-to-end training of multi-document reader and retriever for open-domain question answering. *Advances in Neural Information Processing Systems*, 34: 25968–25981.
- Wang, Y.; Ma, X.; and Chen, W. 2023. Augmenting Black-box LLMs with Medical Textbooks for Clinical Question Answering. *arXiv preprint arXiv:2309.02233*.
- Yu, D.; Zhu, C.; Fang, Y.; Yu, W.; Wang, S.; Xu, Y.; Ren, X.; Yang, Y.; and Zeng, M. 2021. Kg-fid: Infusing knowledge graph in fusion-in-decoder for open-domain question answering. *arXiv preprint arXiv:2110.04330*.
- Zhou, M.; Shi, Z.; Huang, M.; and Zhu, X. 2020. Knowledge-aided open-domain question answering. *arXiv preprint arXiv:2006.05244*.
- Zhu, Y.; Yuan, H.; Wang, S.; Liu, J.; Liu, W.; Deng, C.; Dou, Z.; and Wen, J.-R. 2023. Large Language Models for Information Retrieval: A Survey. *arXiv preprint arXiv:2308.07107*.



## Heterogeneous Document Graph Statistics

The Table 4 reports the statistics of the document graph domain wise.

Table 4: S2ORC Knowledge Graph Statistics.

Scientific Domain	#Nodes			#Links		
	Papers	Authors	Venues	Paper-writes-Author	Paper-PublishedIn-Venue	Paper-cites-Paper
Art	1911954	1084868	62244	2466562	293012	67566
Biology	7331543	6514119	53775	21362778	881701	10080386
Business	3105463	2392490	91310	5197775	536536	791937
Chemistry	9704121	7605776	59378	31548346	833327	2942550
Computer Science	10079285	6700984	263147	25190878	4852428	25890139
Economics	3259612	1856345	58804	5623986	291409	4926950
Engineering	8139131	6489295	100977	18123052	1399082	3215152
Environmental Science	1811696	2202507	44863	4553526	319323	136134
Geography	2978349	2693235	78629	5822277	394774	221624
Geology	2729089	2202712	30510	7637245	355179	4840140
History	2876722	1323615	86920	3548622	374663	142664
Materials Science	7147352	6258034	63829	22680518	1173532	2718010
Mathematics	4163967	2611249	136469	8186619	635732	6391187
Medicine	28504536	18078042	112321	98334667	17419463	67694337
Philosophy	1219530	606965	55551	1418267	204771	125500
Physics	6501506	3814657	420139	28145181	1211603	4771985
Political Science	3933917	2268650	126063	5495180	693493	489718
Psychology	5144736	3563474	104041	9731235	720134	3618670
Sociology	3993869	1982767	92229	5338489	347194	1475856

## Benchmark Examples

## Atlas

"# Below is an input containing a title-abstract pair. Classify this input into one or more possible Field of Study categories ['..']

# Input: ## Title: Characterization of N-Glycosylation Status of Micro-level Glycoprotein Using Solid Phase Extraction Based Techniques.

## Abstract: A new strategy integrating the latest hydrophilic interaction chromatographic(HILIC) method with mass spectrometry technologies was developed for the enrichment and determination of intact glycopeptides and glycan structures from a glycoprotein. The average molecular weight, the ratio of glycosylation, the glycosite and the structures of glycoforms of ribonuclease B(RNaseB) were determined by MALDI-TOF-MS and ESI-LTQ-FT-MS. RNaseB contains 8.43% glycan and has a single glycosylation site at Asn34 with the glycan structure varied from five to nine mannose residues(Man5-9GlcNAc2). The strategy paves the way for systematic and confident analysis of complex glycoproteins with important biological or pharmaceutical functions.

Response: **Chemistry**

Evidence traces:

Passage 1: **[Geology]** Title: Paleomagnetic reversals in Miocene dikes, and tectonic evolution of the Crossman block, Mohave Mountains, Arizona

Passage 2: **[Social Science]** Title: Q&A with Photographer Paul Vecsei

## Atlantic

"# Below is an input containing a title-abstract pair. Classify this input into one or more possible Field of Study categories ['..']

# Input: ## Characterization of N-Glycosylation Status of Micro-level Glycoprotein Using Solid Phase Extraction Based Techniques ## Abstract: A new strategy integrating the latest hydrophilic interaction chromatographic(HILIC) method with mass spectrometry technologies was developed for the enrichment and determination of intact glycopeptides and glycan structures from a glycoprotein. The average molecular weight, the ratio of glycosylation, the glycosite and the structures of glycoforms of ribonuclease B(RNaseB) were determined by MALDI-TOF-MS and ESI-LTQ-FT-MS. RNaseB contains 8.43% glycan and has a single glycosylation site at Asn34 with the glycan structure varied from five to nine mannose residues(Man5-9GlcNAc2). The strategy paves the way for systematic and confident analysis of complex glycoproteins with important biological or pharmaceutical functions.

Response: **Chemistry**

Evidence traces:

Passage 1: **[Chemistry/Biology]** Title: Aryl hydrocarbon receptor in combination with Stat1 regulates LPS-induced inflammatory responses

Passage 2: **[Chemistry/Biology]** Title: Osteogenic protein-1 attenuates the inflammatory cytokine-induced NP cell senescence through regulating the ROS/NF- $\kappa$ B pathway.

Figure 3: Example generations from ATLAS and ATLANTIC models in SciRepEval-FoS (Singh et al. 2022) task. We color the input query in gray, and the generated answer in red. We list three passages as retrieved by the model to support the answer. We annotate each document by the corresponding scientific domain.

## Atlas

"# question: Which of the following is the most likely benefit of periodic natural wildfires in some forest ecosystems? options: (A) The fires remove dead and decaying plant matter, reducing the risk of more intense and destructive fires. (B) The fires leach nutrients from the soil, preventing the germination of plants that might compete with native species. (C) The fires drive off herbivores whose plant-based diets reduce the amount of vegetation. (D) The fires dry out the soil and decrease the chance of flooding after heavy rains.

Response: **A**

Evidence traces:

Passage 1: [Art, History] Title: THE 'LAST BOLSHEVIK' - MARKER,C

Passage 2: [Maths, Engineering] Title: C Frame Transformations

## Atlantic

"# question: Which of the following is the most likely benefit of periodic natural wildfires in some forest ecosystems? options: (A) The fires remove dead and decaying plant matter, reducing the risk of more intense and destructive fires. (B) The fires leach nutrients from the soil, preventing the germination of plants that might compete with native species. (C) The fires drive off herbivores whose plant-based diets reduce the amount of vegetation. (D) The fires dry out the soil and decrease the chance of flooding after heavy rains.

Response: **A**

Evidence traces:

Passage 1: [Geology] Title: Another Threat to Borneo's Rainforests?

Passage 2: [Geology] Title: The potential of secondary forests

## Atlas

"# question: The Minoan economy may have been especially vulnerable to natural catastrophe because it relied heavily on : options: (A) agriculture (B) maritime trade (C) metalworking (D) slave labor answer

Response: **B**

Evidence traces:

Passage 1: [Computer science] Title: B Unicode Representation

Passage 2: [Maths, Engineering] Title: C Frame Transformations

## Atlantic

"# question: The Minoan economy may have been especially vulnerable to natural catastrophe because it relied heavily on: options: (A) agriculture (B) maritime trade (C) metalworking (D) slave labor answer

Response: **B**

Evidence traces:

Passage 1: [Economics] Title: Public debt and endogenous growth

Passage 2: [Economics] Title: Land and rent

Figure 4: Example generations from ATLAS and ATLANTIC models in MMLU task. Accurate retrieval from ATLANTIC but inaccurate retrieval from ATLAS. We color the input query in gray, and the generated answer in red. We list two passages as retrieved by the model to support the answer. We annotate each document by the corresponding scientific domain.

## Atlas

"# question: In a command economy options: (A) the market dictates the answers to the fundamental economic questions. (B) competition helps answer the fundamental economic questions. (C) state and local governments respond to the fundamental economic questions. (D) the central government dictates the answers to the fundamental economic questions.

Response: **D**

Evidence traces:

Passage 1: [Computer science] Title: Concurrency in C

Passage 2: [social science] Title: Discussion and reprise

## Atlantic

"# question: In a command economy options: (A) the market dictates the answers to the fundamental economic questions. (B) competition helps answer the fundamental economic questions. (C) state and local governments respond to the fundamental economic questions. (D) the central government dictates the answers to the fundamental economic questions.

Response: **D**

Evidence traces:

Passage 1: [Art] Title: Focus on Feathers

Passage 2: [Social science] Title: Time to Hope: Cathedral of St. John the Divine, New York Museo De San Francisco, Santiago De Chile

## Atlas

"# question: During the investigation of a chemical reaction by a chemistry student, she was able to determine that the reaction was nonspontaneous at 1 atm and 298 K. However, she learned that cooling the system with dry ice (-78°C) caused the reaction to become spontaneous. Which of the following combinations must apply to this reaction? options: (A)  $\Delta H < 0$ ,  $\Delta S < 0$ , and  $\Delta G = 0$  (B)  $\Delta H > 0$ ,  $\Delta S < 0$ , and  $\Delta G > 0$  (C)  $\Delta H < 0$ ,  $\Delta S < 0$ , and  $\Delta G > 0$  (D)  $\Delta H > 0$ ,  $\Delta S > 0$ , and  $\Delta G > 0$

Response: **C**

Evidence traces:

Passage 1: [History] Title: A Flight of Swallows

Passage 2: [Mathematics] Title: Rank Transformations

## Atlantic

"# question: During the investigation of a chemical reaction by a chemistry student, she was able to determine that the reaction was nonspontaneous at 1 atm and 298 K. However, she learned that cooling the system with dry ice (-78°C) caused the reaction to become spontaneous. Which of the following combinations must apply to this reaction? options: (A)  $\Delta H < 0$ ,  $\Delta S < 0$ , and  $\Delta G = 0$  (B)  $\Delta H > 0$ ,  $\Delta S < 0$ , and  $\Delta G > 0$  (C)  $\Delta H < 0$ ,  $\Delta S < 0$ , and  $\Delta G > 0$  (D)  $\Delta H > 0$ ,  $\Delta S > 0$ , and  $\Delta G > 0$

Response: **C**

Evidence traces:

Passage 1: [Biology] Title: Inhibition of cellular protein secretion by picornaviral 3A proteins

Passage 2: [Physics, Geology] Title: The risky road to Mars

Figure 5: Example generations from ATLAS and ATLANTIC models in MMLU benchmark with related inaccurate retrieval to support accurate model predictions. We color the input query in gray, and the generated answer in red. We list two passages as retrieved by the model to support the answer. We annotate each document by the corresponding scientific domain.